



CRUMBLER

ALTINBILEK Crumbler ensure that pelleted products are broken in a perfect balance at every point in desired particle sizes. In pellet presses, it is used to bring the existing pellet to the desired particle size in a balanced way instead of instant die change. Each of the rolls that perform the crushing process are driven at different speeds by separate gearmotors. Coupling and joint connection systems are used for power transmission to the rolls. In order to ensure that the pelleted products are crushed in desired sizes using minimum energy, special tooth structure channels are opened on the roller surfaces and the rollers are subjected to surface hardening heat treatment. Thanks to this design, the pellet is prevented from crushing, and it is ensured to be crushed in granular form by cutting method. Altinbilek Crumbler has an electro-pneumatically controlled cover system in order to control the entry of goods into the system and prevent the accumulation of raw materials on the rolls. There is also an electro-pneumatic controlled by-pass flap system within this section. Thanks to the by-pass system, if deemed necessary, pelleted products can be passed through the granulator without breaking. There is a reducer motor driven drum type feeding system at the entrance. The feeding system is used to ensure a balanced distribution of incoming pelleted products on the roll and to control the inlet flow. The pellet entrance opening can be adjusted in the feeding system. In order to determine the capacity and particle size in the crushing process, it is possible to adjust the gap between the rolls. A spring system is applied to prevent damage to the rolls and system. There is a wide observation and control cover on each roll group and sampling apparatus at the exit. Thus, the entire flow from the incoming pellet to the granulated product can be observed and controlled easily. Altinbilek Granulators offer manual and automatic roll gap adjustment options to their operators.

FEATURES

- High and Balanced Crushing Capacity
- High Transmittance Rate
- Bolt Combined Modular Structure
- Effective Powder Sealing Elements
- Heavy Duty Block Bearings
- Easy Use and Maintenance

DRIVE SYSTEM

- Geared Motor
- IE3 Class High Efficiency Electric Motor (IE4 - Optional)
- Coupling and Joint Connection Power Transmission System

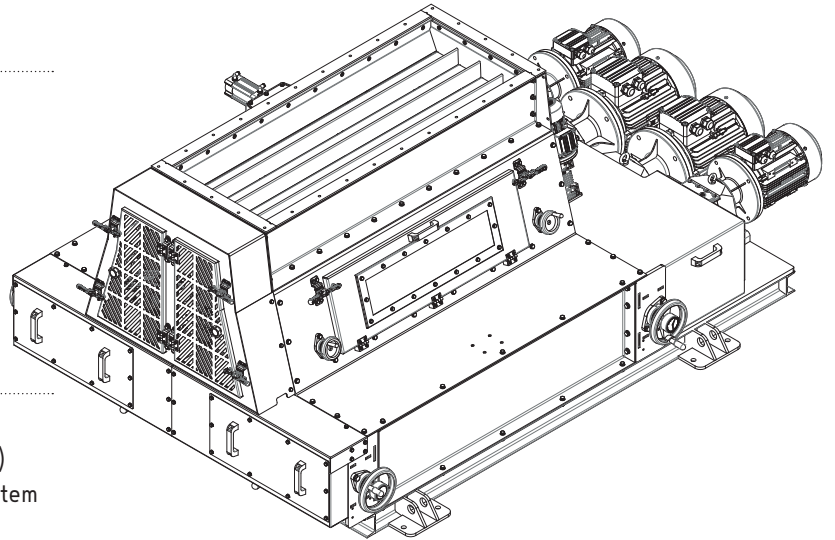

SECURITY SYSTEM

- Feeder Tour Sensor
- Directional Flap Sensor
- Safety Sensor on Covers
- Bearing Heat Detection Sensor (Optional)

ACCESSORIES

- Electro-Pneumatic Controlled By-Pass Flap
- Easy to Open Maintenance and Intervention Cover
- Exit Sampling Apparatus
- Vibration Absorbing Rubber Wedges
- Closed Type Casing

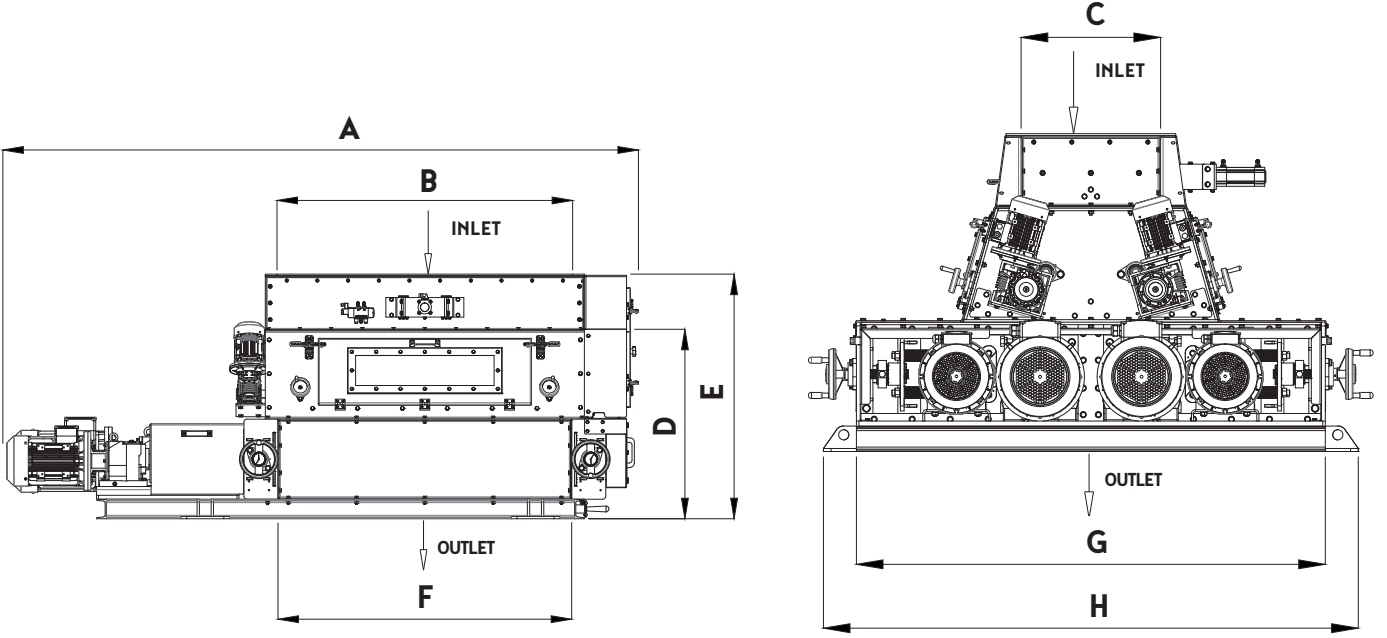

Type	Motor Power (kW x Qty.)	Feeder Motor Power (kW x Qty.)	Roller Dimen- sions x Qty.	Dimensions (mm)							
				A	B	C	D	E	F	G	H
GV2100	5,5 kW x1+4kWx1	0,75 kW	Ø250 X	2.420	1.015	300	965	1.175	1.000	950	1.210
GV2150	11 kW x1+7.5kWx1	0,75 kW	Ø250 X	3.000	1.515	300	965	1.175	1.500	950	1.210
GV4150	11 kW x2+7.5kWx2	0,75 kW x 2	Ø250 X	3.215	1.515	550	965	1.255	1.500	1.850	2.110

The designs and dimensions may be modified without notice.